



SPECIFICATION FOR SMT OSCILLATOR MtronPTI P/N M2002S422

I. GENERAL & ELECTRICAL REQUIREMENTS:

1. FREQUENCY: 61.440000 MHz
2. FREQUENCY STABILITY: ± 50 ppm (Includes initial tolerance and deviation over temperature)
3. OPERATING TEMPERATURE RANGE: -55°C to $+125^{\circ}\text{C}$
4. OPERATING VOLTAGE (Vdd): $3.3\text{ V} \pm 0.3\text{ V}$
5. OPERATING CURRENT: 30 mA max.
6. OUTPUT TYPE: HCMOS Compatible
7. SYMMETRY: 40/60% ref. to $\frac{1}{2}$ Vdd
8. RISE/FALL TIME: 4 nS max. ref. 10% to 90% Vdd
9. OUTPUT LOGIC LEVELS: $V_{OL} = 10\%$ Vdd max. $V_{OH} = 90\%$ Vdd min.
10. OUTPUT LOAD: 15 pF max.
11. TRISTATE FUNCTION (Pad 1): Logic "1" enables output. Logic "0" disables output to a high impedance.

II. ENVIRONMENTAL & MECHANICAL REQUIREMENTS:

1. SHOCK: MIL-STD-202, Method 213, Condition C.
2. VIBRATION: MIL-STD-202, Methods 201 & 204.
3. HERMETICITY: 1×10^{-8} atm cc/sec min.
4. STORAGE TEMPERATURE: -55°C to $+125^{\circ}\text{C}$
5. SOLDERABILITY: Per EIAJ-STD-002
6. REFLOW SOLDER CONDITIONS: See Figure 1
7. PACKAGE: 4 - Pad leadless ceramic. Pb free package (M2 type)

Figure 1

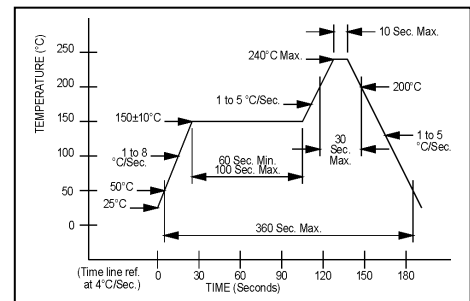

III. DIMENSIONS:

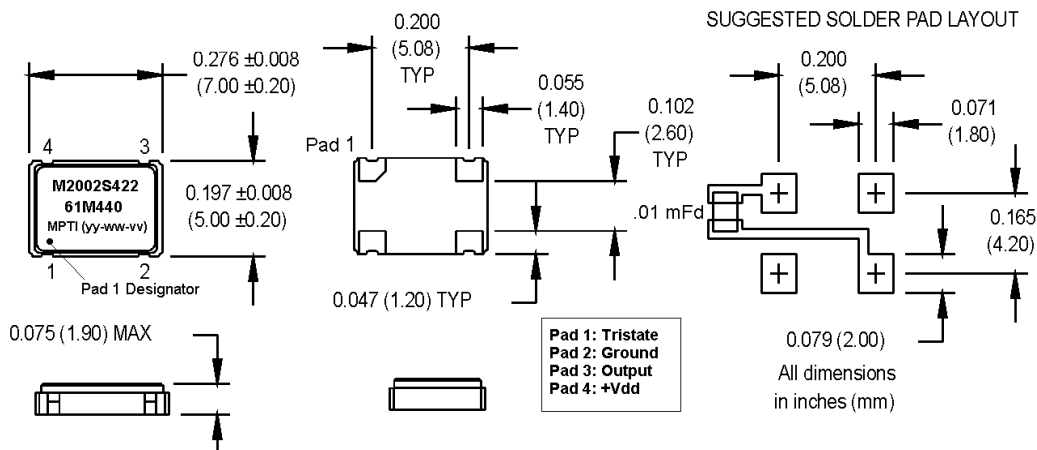

IV. DATA SHEET REVISION TABLE:

Date	Rev.	Author	Details of Revision
6/8/05	0	WNJ	Original release.
6/9/05	A	WNJ	Added lead (Pb) designation to the data sheet information.