



## SPECIFICATION FOR RoHS 6 COMPLIANT HCMOS SMT OSCILLATOR MtronPTI P/N: M2002T057

### Electrical Specifications:

Parameter	Symbol	Min.	Typ.	Max.	Units	Conditions
Frequency of Operation	F <sub>o</sub>		25.001875		MHz	
Frequency Stability	ΔF/F	-25		+25	ppm	Inclusive of initial tolerance at +25°C, deviation over temperature, shock, vibration, voltage & load variations and aging
Operating Temperature	T <sub>A</sub>	-40		+85	°C	
Storage Temperature	T <sub>S</sub>	-55		+125	°C	
Aging		-3		+3	ppm	1 <sup>st</sup> year
		-2		+2	ppm	Thereafter (per year)
Operating Voltage	V <sub>DD</sub>	2.97	3.3	3.63	V	
Operating Current	I <sub>DD</sub>			20	mA	
Output Type		HCMOS Compatible				
Output Load		15			pF	
Symmetry (duty cycle)	T <sub>DC</sub>	45		55	%	@ 50% of V <sub>DD</sub>
Logic "1" Level	V <sub>OH</sub>	90% V <sub>DD</sub>			V	HCMOS load
Logic "0" Level	V <sub>OL</sub>			10% V <sub>DD</sub>	V	HCMOS load
Rise/Fall Time	T <sub>R</sub> /T <sub>F</sub>			6.0	nS	From 10% to 90% V <sub>DD</sub>
Tri-state Enable Logic		80% V <sub>DD</sub> or N/C			V	Pad 1. Clock Signal Output
Tri-state Disable Logic				20% V <sub>DD</sub>	V	Pad 1. Output to high-Z
Random Jitter	R <sub>J</sub>			12	pS RMS	1-Sigma
Start-up Time	T <sub>SU</sub>		5		mS	

### Environmental Conditions:

Mechanical Shock	Per JESD22-B-104-A 1500g Peak 0.5 msec duration 5 pulses in 6 directions
Vibration	Per JESD22-B-103-A 20g Peak (20-2000 Hz) in X, Y and Z directions
Thermal Cycle	Per MIL-STD-883, Method 1010, B (-55°C to 125°C, 15 min. dwell, 10 cycles)
Hermeticity	Per MIL-STD-202, Method 112 (1 x 10 <sup>-8</sup> atm cc/s of Helium)
ESD-Human Body Model	2000 volts; Per JESD22A-114-A
ESD-Machine Model	200 volts; Per JESD22A-115-A
Solderability	Per EIAJ-STD-002
Max. Soldering Conditions	See solder profile, Figure 1
Package Type	5.0 x 7.0 x 1.7 mm, 4-pad Ceramic Leadless Chip Carrier (M2 type)
Termination (Pad) Material	10 to 15 μm of tungsten (W), 1.29 to 8.89 μm of nickel (Ni), 0.3 to 1.0 μm of gold (Au)
Moisture Sensitivity Level	1

## SPECIFICATION FOR RoHS 6 COMPLIANT HCMOS SMT OSCILLATOR MtronPTI P/N: M2002T057

### Mechanical, Marking and Layout Information:

Pad	Function
1	Tri-state
2	Ground
3	Output
4	+V <sub>DD</sub>

Part Marking	
Line 1	M2002T057
Line 2	25M0018
Line 3	M yy ww vv

Legend	
yy	Year
ww	Work week
vv	Factory code

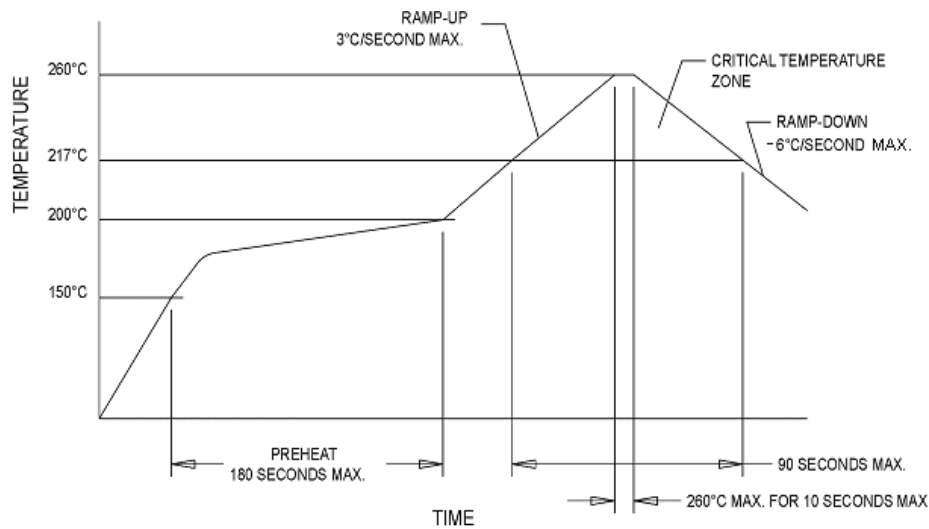
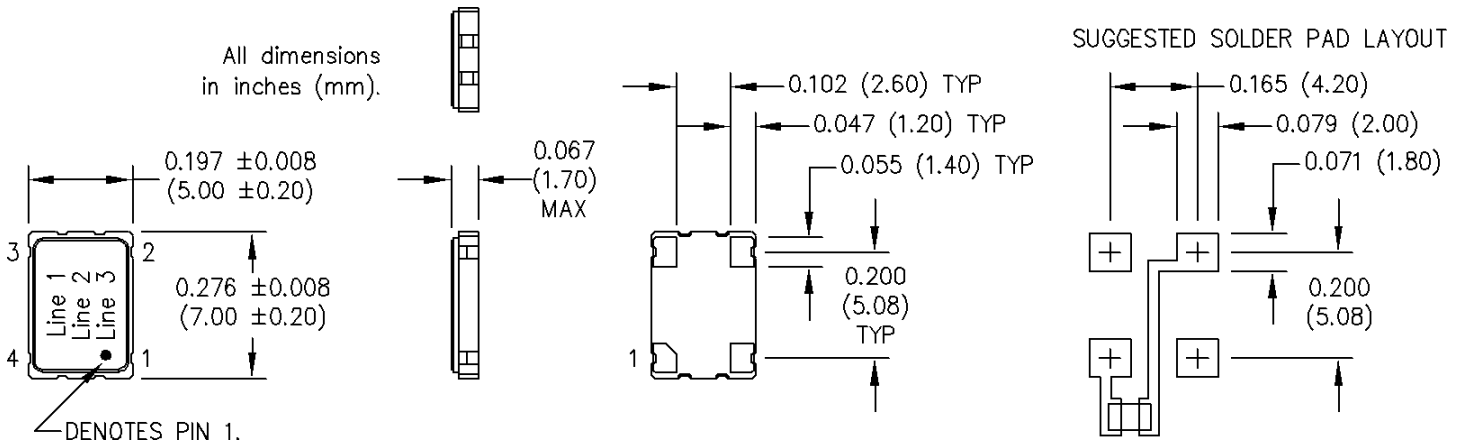

Figure 1

### Datasheet Revision Table:

Date	Rev.	Author	Details of Revision
11/23/10	0	DDM	Original release.